

FEIDER



PLASTER VACUUM

FAP1430

USER GUIDE

CAUTION: Read the instructions before using the machine !

CONTENTS

1. SAFETY INSTRUCTIONS.....	3
2. THE PRODUCT.....	6
3. ASSEMBLY.....	7
4. USE.....	8
5. MAINTENANCE.....	10
6. DISPOSAL.....	10
7. DECLARATION OF CONFORMITY.....	11
8. WARRANTY.....	12
9. PRODUCT FAILURE.....	13
10. WARRANTY EXCLUSIONS.....	14

1. SAFETY INSTRUCTIONS

- This appliance can be used by children aged from 8 years and above and persons with reduced physical, sensory or mental capabilities or lack of experience and knowledge if they have been given supervision or instruction concerning use of the appliance in a safe way and understand the hazards involved. Children shall not play with the appliance. Cleaning and user maintenance shall not be made by children without supervision.
- If the supply cord is damaged, it must be replaced by the manufacturer, its service agent or similarly qualified persons in order to avoid a hazard.
- Check that the mains voltage corresponds to the details on the type plate.
- Only connect to a proper 220-240 volt, 50/60Hz socket.
- Minimum fuse protection 13A.
- Pull the mains plug out of the socket when: the unit is not in use, before opening the unit, before cleaning and maintenance.

- Never clean with solvents.
- Do not use the cable to pull the plug out of the socket.
- When unit is ready for use, do not leave unattended Safeguard from children.
- Care must be taken that the mains connection lead is not damaged by being driven over, crushed, stretched, etc.
- The unit must not be operated if the mains connection lead is not in perfect condition.
- If the supply cord is damaged, it must be replaced by the manufacturer or its service agent to a similarly qualified person in order to avoid a hazard.
- On no account vacuum: burning matches, glowing ashes and cigarette ends, inflammable, corrosive, fire hazard or explosive substances, vapours and liquids
- This unit is not suitable for vacuuming dust which is damaging to health.
- Store the unit in a dry place.
- Do not operate a deflection unit.
- Servicing only by an authorized after-sales service point.

- Use only for operations for which the unit is intended.
- Take great care when cleaning stairs.
- Use only manufacturer's attachments and spare parts.
- This appliance is not intended for use by persons (including children) with reduced physical, sensory or mental capabilities, or lack of experience and knowledge, unless they have been given supervision or instruction concerning use of the appliance by a person responsible for their safety.
- Children should be supervised to ensure that they do not play with the appliance.
- **IPX4 is only granted by connect an IPX4 plug to socket-out of the appliance or the cover of the socket-out is closed.**
- **Max. load of socket-out: 2000W.**

2. THE PRODUCT

Technical data:

1. Rated power: 3400W (1400W motor, max. load of socket-out: 2000W)

2. Voltage: 220-240V

3. Frequency: 50/60Hz

4. Insulation class: Class I



Items supplied:

- | | | | |
|----|------------------------|-----|----------------------|
| 1、 | Handle | 10、 | Flexible vacuum hose |
| 2、 | ON/OFF switch | 11、 | Vacuum tube |
| 3、 | Top section | 12、 | air inlet |
| 4、 | Filter basket | 13、 | Large vacuum nozzle |
| 5、 | Transparent window | 14、 | Cotton bag |
| 6、 | Clasp | 15、 | Crevice nozzle |
| 7、 | Upper Tank | 16、 | Speed controller |
| 8、 | Vacuum hose connection | 17、 | Socket outlet |
| 9、 | Idler wheel | 18、 | Bottom Tank |

Overview of nozzles

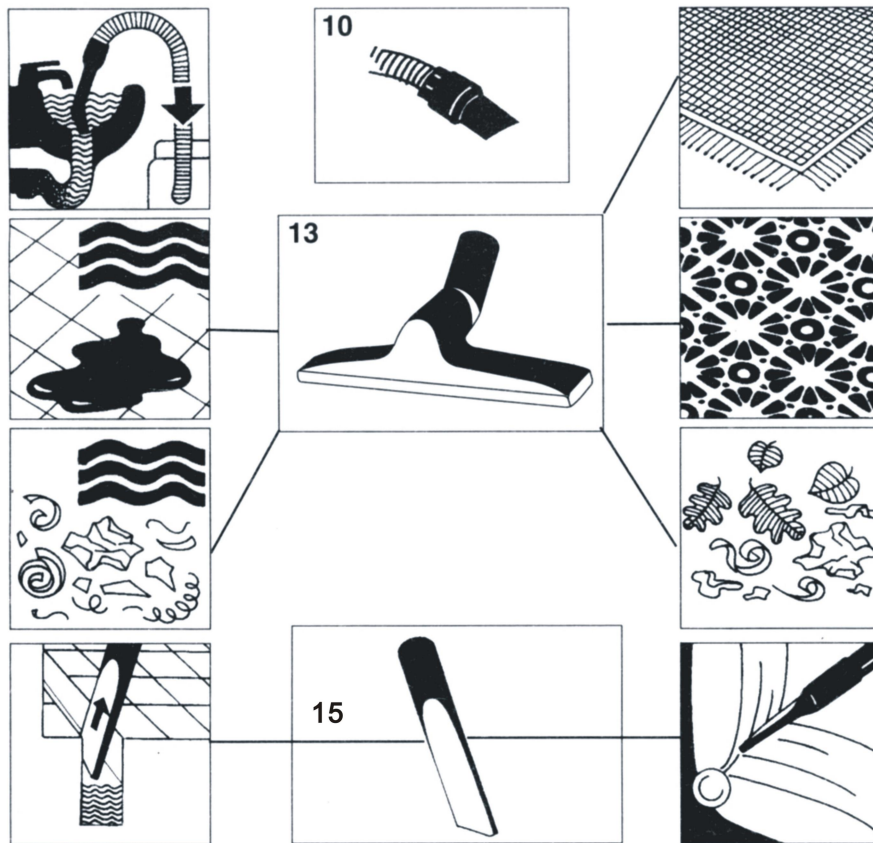

3. ASSEMBLY

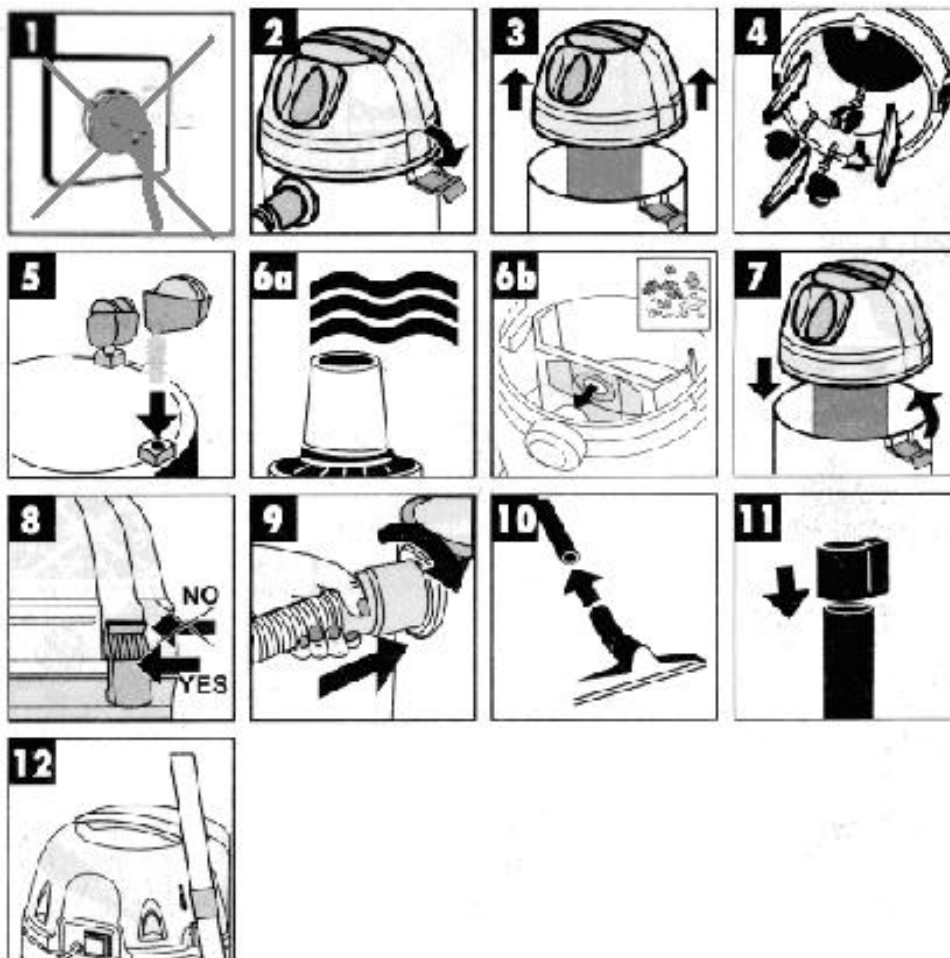

Please note:

Figure 6a:Use the supplied foamed plastic filter for wet vacuum-cleaning

Figure 6b:Use the supplied dust bag for dry vacuum-cleaning

Insert the plug and turn on the switch, then appliance starts to work (Figure 4 & 5a or 5b)

When push the switch to the “I” position, the vacuum cleaner will work; when push the switch to the “O” position, vacuum cleaner will not work.

The outer facility for the socket’s power is below 2000W.

The dust bag included upon delivery is not suitable for wet vacuum-cleaning!

4. USE

Wet vacuum - cleaning

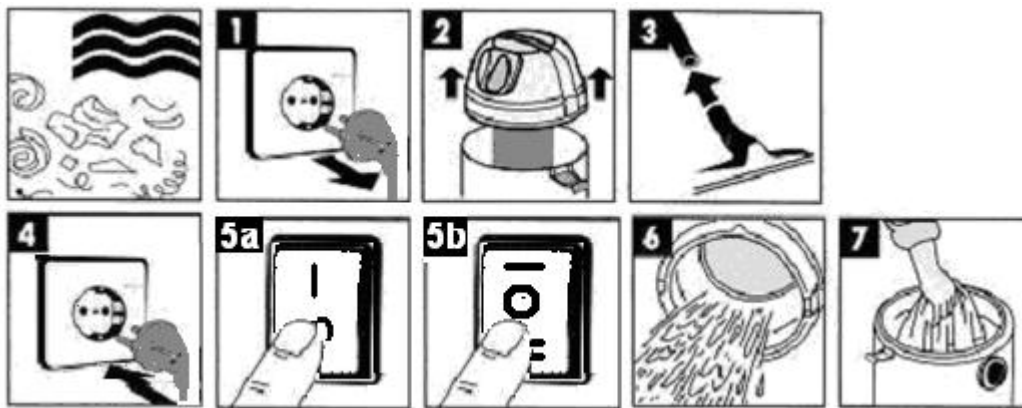

Unplug before change filter (Figure 1)

Pull the supplied foamed plastic filter over the filter basket (Figure 2) for wet vacuum-cleaning.

Insert the plug and turn on the switch, then appliance starts to work (Figure 4 & 5a or 5b)

When push the switch to the “I” position, the vacuum cleaner will work alone; when push the switch to the “O” position, vacuum cleaner will not work; when push the switch to the “II” position, while the tool which is connected with the socket working, the vacuum cleaner also work 3-5 seconds later, while the tool stop working, the vacuum cleaner also stop working.

Pls note:When use wet function,install the hose into upper tank,use upper tank and brush to suction water.After wet use,pull out water and clean the tank.

The outer facility for the socket’s power is below 2000W.

The dust bag included upon delivery is not suitable for wet vacuum-cleaning!

Dry vacuum-cleaning

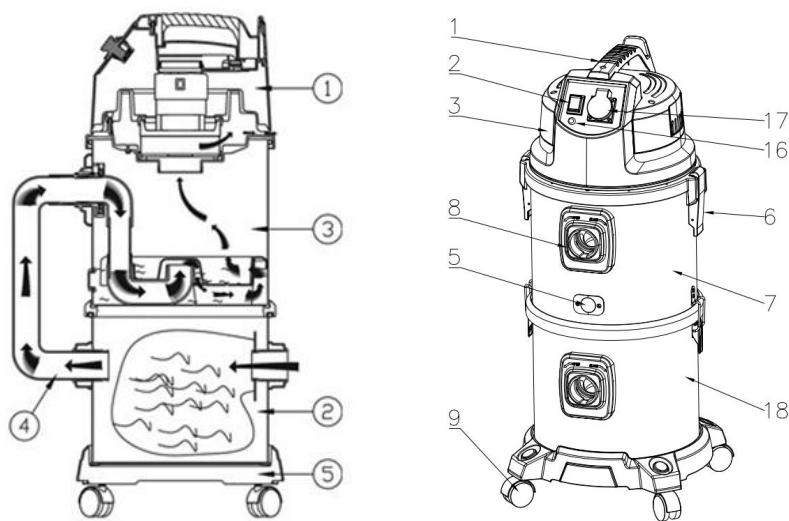
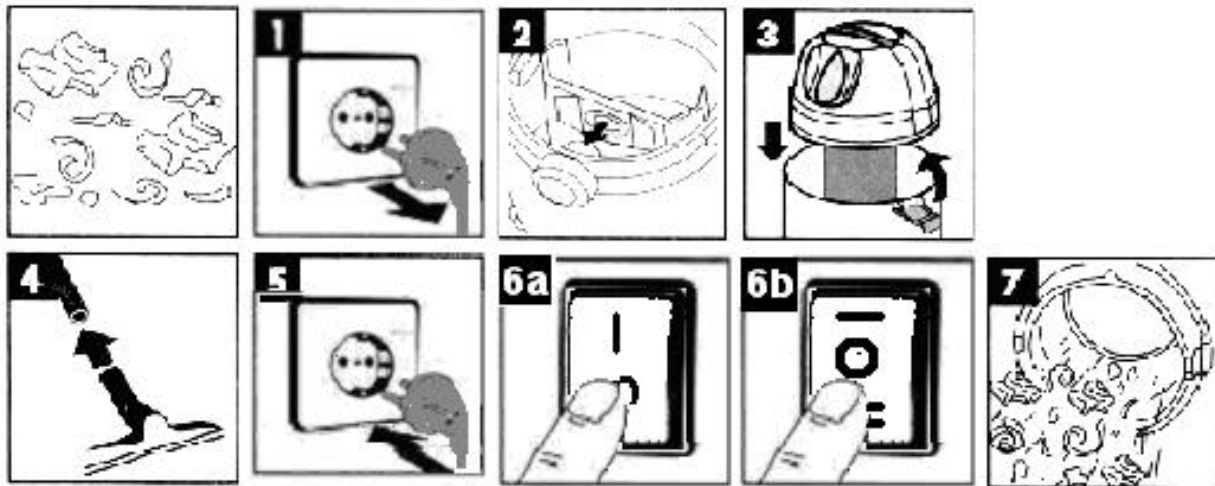

Unplug before change filter (Figure 1), then take out the bag and empty the dust or replace the bag. Slip the dust bag onto the socket (figure 2) for dry vacuum-cleaning.

Insert the plug and turn on the switch, then appliance starts to work (Figure 5 & 6a or 6b)

When push the switch to the “I” position, the vacuum cleaner will work; when push the switch to the “O” position, vacuum cleaner will not work. when push the switch to the “II” position, while the tool which is connected with the socket working, the vacuum cleaner also work 3-5 seconds later, while the tool stop working, the vacuum cleaner also stop working.

The outer facility for the socket's power is below 2000W.

The dust bag is suitable only for dry vacuum-cleaning!

Pls note: The dry function is mostly use with sanders,

1. Assemble the connect hose between the upper tank and bottom tank like (left hand 4)
2. Assemble the dust bag into the bottom tank (like left hand 2)
3. Put in some water in upper tank, the water level should be in middle through the transparent window. (like right hand 5)
4. Insert the sander plug into the “right hand 17” socket, the vacuums switch turn to “6b”, then turn on sanders switch for sanders using.
5. Switch “6b” is only used when vacuums connect with sanders.

The dust bag is suitable only for dry vacuum-cleaning!

5. MAINTENANCE

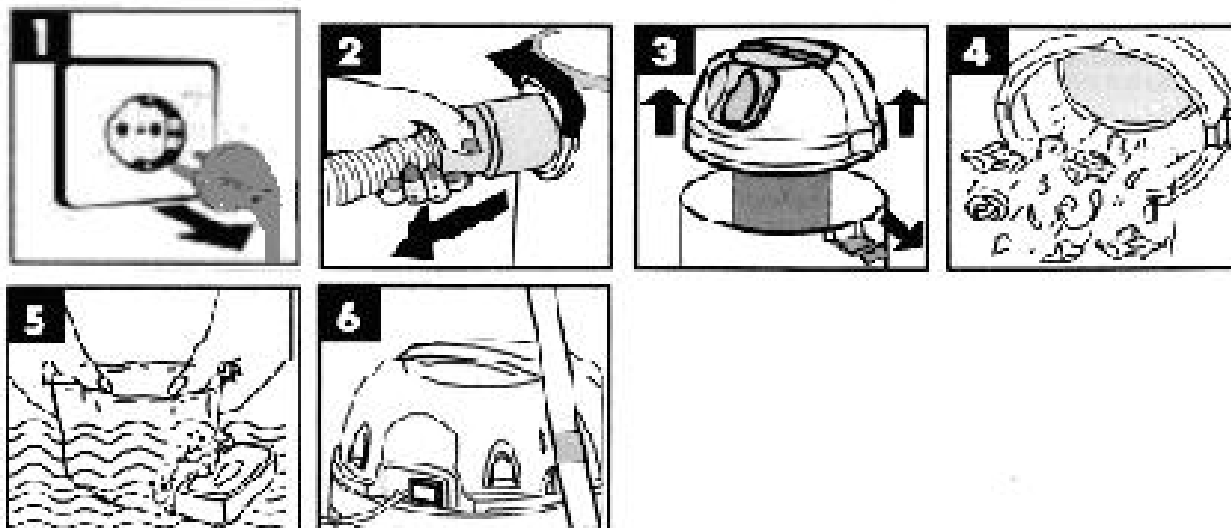

Unplug before maintenance (Figure 1)

Take off the foamed plastic filter (Figure 3), and wash by water (Figure 5)

IMPORTANT: Do not use detergents to clean the filter. The filter must be thoroughly dry before the machine is used.

6. DISPOSAL

Correct Disposal of this product



This marking indicates that this product should not be disposed with other household wastes throughout the EU. Electric and electronic equipment can be hazardous for the environment and for human health since they contain hazardous substances. To prevent possible harm to the environment or human health from uncontrolled waste disposal, recycle it responsibly to promote the sustainable reuse of material resources. To return your used device, please use the return and collection systems or contact the retailer where the product was purchased. They can take this product for environmental safe recycling.

7. DECLARATION OF CONFORMITY



BUILDER SAS

ZI - 32 rue aristide Bergès - 31270 Cugnaux - France

Tel : +33 (0)5.34.502.502 Fax : +33 (0)5.34.502.503

States that the designated below machine :

PLASTER VACUUM

Model: FAP1430

S/N: 20240605906-20240606105

is in conformity with the essential requirements and other relevant provisions of the applicable European Directives, based on the application of European harmonized standards. Any unauthorized modification of the apparatus voids this declaration.

Satisfies the requirement of the Council Directives:

EC- Low voltage directive 2014/35/EU

EC Directive of Electromagnetic Compatibility 2014/30/EU

Rohs Directive 2011/65/EU & (EU) 2015/863

and conforms with the norms:

EN 60335-1:2012+A11:2014+A13:2017+A1:2019+A2:2019+A14:2019+A15:2021

EN 60335-2-2:2010+A11:2012+A1:2013

EN 62233 : 2008

EN IEC55014-1:2021

EN IEC55014-2:2021

EN IEC61000-3-2:2019+A1:2021

EN 61000-3-3:2013+A1:2019+A2:2021

Done at Cugnaux : 08/05/2024

Philippe MARIE/PDG

8. WARRANTY

The manufacturer guarantees the product against defects in material and workmanship for a period of 2 years from the date of the original purchase. It can be extended by one year if the user subscribes to website of myswap. The warranty only applies if the product is for household use. The warranty does not cover breakdowns due to normal wear and tear.

The manufacturer agrees to replace parts identified as defective by the designated distributor. The manufacturer does not accept responsibility for the replacement of the machine, in whole or in part, and/or ensuing damage.

The warranty does not cover breakdowns due to:

- insufficient maintenance.
- abnormal assembly, adjustment or operations of the product.
- parts subject to normal wear and tear.

The warranty does not extend to:

- shipping and packaging costs.
- using the tool for a purpose other than that for which it was designed.
- the use and maintenance of the machine done in a manner not described in the user manual.

Due to our policy of continuous product improvement, we reserve the right to alter or change specifications without notice. Consequently, the product may be different from the information contained therein, but a modification will be undertaken without notice if it is recognized as an improvement of the preceding characteristic.

READ THE MANUAL CAREFULLY BEFORE USING THE MACHINE.

When ordering spare parts, please indicate the part number or code, you can find this in the spare parts list in this manual. Keep the purchase receipt; without it, the warranty is invalid. To help you with your product, we invite you to contact us by phone or via our website:

+33 (0)9.70.75.30.30

<https://services.swap-europe.com/contact>

You must create a "ticket" via the web platform.

- Register or create your account.
- Indicate the reference of the tool.
- Choose the subject of your request.
- Describe your problem.

Attach these files: invoice or sales receipt
photo of the identification plate (serial number), photo of the part you need (for example: pins on the transformer plug which are broken).



9. PRODUCT FAILURE

WHAT TO DO IF MY MACHINE BREAKS DOWN?

If you bought your product in a store:

- Make sure that your machine is complete with all accessories supplied, and clean! If this is not the case, the repairer will refuse the machine.
- Go to the store with the complete machine and with the receipt or invoice.

If you bought your product on a website:

- Make sure that your machine is complete with all accessories supplied, and clean! If this is not the case, the repairer will refuse the machine.
- Create a SWAP-Europe service ticket on the site: <https://services.swap-europe.com> When making the request on SWAP-Europe, you must attach the invoice and the photo of the nameplate (serial number).

Contact the repair station to make sure it is available before dropping off the machine.

Go to the repair station with the complete machine packed, accompanied by the purchase invoice and the station support sheet downloadable after the service request is completed on the SWAP-Europe site

Please keep your original packaging to allow for after-sales service returns or pack your machine with a similar cardboard box of the same dimensions.

For any question concerning our after-sales service you can make a request on our website <https://services.swap-europe.com>

Our hotline remains available at +33 (9) 70 75 30 30.



10. WARRANTY EXCLUSIONS

THE WARRANTY DOES NOT COVER:

- Start-up and setting up of the product.
- Damage resulting from normal wear and tear of the product.
- Damage resulting from improper use of the product.
- Damage resulting from assembly or start-up not in accordance with the user manual.
- Periodic and standard maintenance events.
- Actions of modification and dismantling that directly void the warranty.
- Products whose original authentication marking (brand, serial number) has been degraded, altered or withdrawn.
- Replacement of consumables.
- The use of non-original parts.
- Breakage of parts following impacts or projections.
- Accessories breakdowns.
- Defects and their consequences linked to any external cause.
- Loss of components and loss due to insufficient screwing.
- Cutting components and any damage related to the loosening of parts.
- Overload or overheating.
- Poor power supply quality: faulty voltage, voltage error, etc.
- Damages resulting from the deprivation of enjoyment of the product during the time necessary for repairs and more generally the costs related to the immobilization of the product.
- The costs of a second opinion established by a third party following an estimate by a SWAP-Europe repair station
- The use of a product which would show a defect or a breakage which was not the subject of an immediate report and/or repair with the services of SWAP-Europe.
- Deterioration linked to transport and storage*.

* In accordance with transport legislation, damage related to transport must be declared to carriers within 48 hours maximum after observation by registered letter with acknowledgement of receipt. This document is a supplement to your notice, a non-exhaustive list.

Attention: all orders must be checked in the presence of the delivery person. In case of refusal by the delivery person, it you must simply refuse the delivery and notify your refusal.

Reminder: the reserves do not exclude the notification by registered letter with acknowledgement within 72 hours.

Information:

Thermal devices must be wintered each season (service available on the SWAP-Europe site). Batteries must be charged before being stored.

FEIDER



CE

BUILDER SAS

32 rue Aristide Bergès - Z.I. du Casque - 31270 Cugnaux - France

Made in PRC